

**AREA:** Farm Mechanics

**UNIT:** Arc Welding

**JOB 16:** Cutting with mild steel electrodes

**SITUATION:**

**OBJECTIVES:**

1. To develop skill in cutting metals with arc welding electrodes.
2. To develop an understanding of practical uses for cutting with the mild steel electrode.
3. To develop safety precautions within the operator when cutting metal.

**MOTIVATION:**

1. Explain the advantages of cutting with arc welding equipment.
  - a. process is quick.
  - b. economical.
  - c. makes use of equipment already on the job.
  - d. good when cutting job is small or hard to reach.
2. Show sample cuts where base metal is of different thicknesses.
3. Bring out heat of electrode as compared to heat of base metal to illustrate speed.

**PREPARATION AND FOLLOW-UP:**

1. Sample cuts.
2. Overhead projector.
3. Transparencies showing electrode movement.
4. Job operation sheets to be passed out to class.
5. Set up welding table for demonstration.
6. The following questions may be used as a follow-up:
  1. What is the difference between amperage adjustments for welding and cutting?
  2. How is the electrode manipulated during the cutting process?
  3. What safety precautions does a welding operator observe when cutting?
  4. Why is it possible to cut metal with the arc welding electrode?
  5. List several practical uses which can be made of the arc welder as a cutting tool.

<u>Steps</u>	<u>Procedure</u>	<u>Safety &amp; Key Points</u>
1. Assemble materials	<ul style="list-style-type: none"> <li>a. Mild steel scrap</li> <li>b. 1/8" mild steel electrodes</li> <li>c. Cutting container to catch hot molten metal</li> <li>d. Grinder</li> <li>e. Welding accessories</li> </ul>	<ul style="list-style-type: none"> <li>1. 1/8" to 1/4" thick</li> <li>1. E 6011 or E 6013</li> </ul>
2. Position metal for cutting	<ul style="list-style-type: none"> <li>a. Place metal so that hot molten metal will fall into container.</li> <li>b. Place metal on edge in upright or vertical position so that cut can be made from the side.</li> </ul>	
3. Adjust amperage	<ul style="list-style-type: none"> <li>a. Use maximum setting for electrode used (140 amps for 1/8")</li> </ul>	<ul style="list-style-type: none"> <li>1. Reduce amperage 10 amps if electrode becomes red hot and coating burns.</li> </ul>
4. Mark metal for cutting	<ul style="list-style-type: none"> <li>a. Use soapstone to mark metal.</li> <li>b. Clamp a piece of scrap metal adjacent to line of cut as a guide.</li> </ul>	
5. Prepare operator and area for cutting	<ul style="list-style-type: none"> <li>a. Roll down cuffs of pants to cover shoe tops.</li> <li>b. Protect body against flying spatter.</li> <li>c. See that all inflammable materials are at a safe distance.</li> </ul>	<ul style="list-style-type: none"> <li>1. Wear protective clothing and gloves.</li> </ul>
6. Cut metal	<ul style="list-style-type: none"> <li>a. Strike arc at top edge of metal, directly above line where cut is to be made.</li> <li>b. When heat of arc melts metal in crater, move electrode tip back and forth into the kerf.</li> <li>c. Weave electrode slightly from side to side to widen kerf.</li> <li>d. Position electrode that the arc is directed at the metal being heated.</li> </ul>	<ul style="list-style-type: none"> <li>1. Force of arc will push molten metal from kerf.</li> <li>1. Approx. 10° in direction of travel.</li> </ul>

7. Examine edge of cut
  - a. Determine if edge is true.
  - b. Use grinder to smooth up surface.

References:

1. Arc Welding Lessons; Harold L. Kugler
2. Farm Mechanics Text & Handbook; Phipps, Cook, McColly, Scranton

# Cutting With Electrode

Quick Upward  
Motion - "Push"  
Molten Metal  
Out with Downward  
Motion.

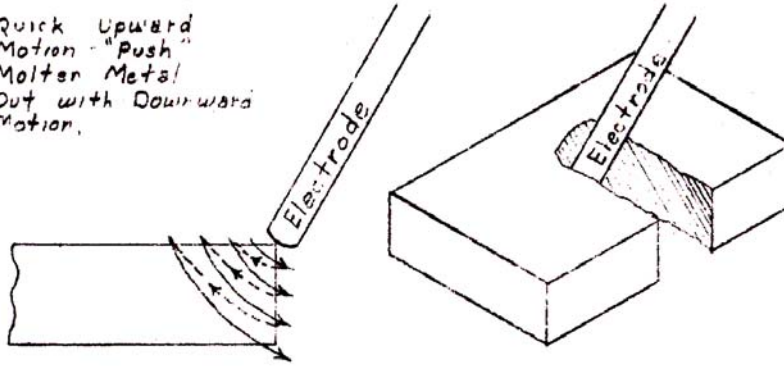

Flat Position

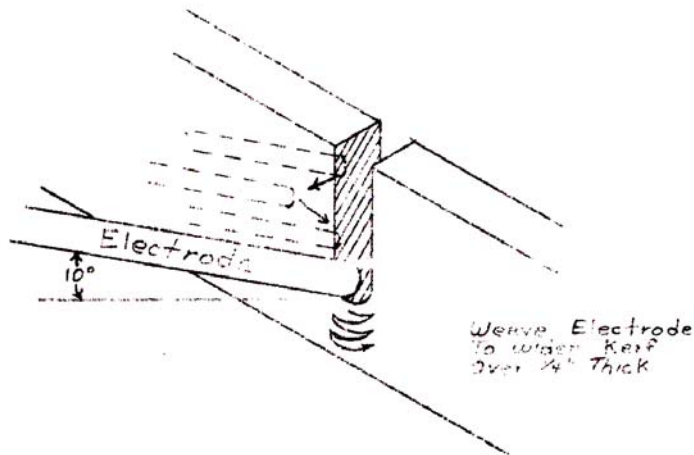

Vertical Position